

PRIMARY APPLICATION

FORD
F-250 Super Duty 4x4 (1999-2016)
F-350 Super Duty 4x4 (1999-2016)

TOOLS REQUIRED

- 1 Floor Jack
- 2 Jack Stands
- 4 Wheel Blocks
- 1 9/16 Wrench
- 1 9/16 Socket

PARTS LIST

Item	QTY	Part#	Description
A	6	512323	3/8-16 Nyloc Nut
B	6	512227	3/8 Flat Washer
C	2	512207	3/8-16 x 3/4" Serrated Flange Bolt
D	2	512349	Mounting Bracket
E	2	511421-38	SumoSprings Black (-47)
F	4	512211	3/8-16 x 3-1/2" Carriage Bolt
G	2	512155	Jounce Pad
H	2	512150	Lower Clamp
I	2	512117	4" x 1" Spacer*
J	2	512274	3/8-16 x 1-3/4" Serrated Flange Bolt*

*Not in diagram

APPROXIMATE INSTALL TIME

🕒 2 Hours

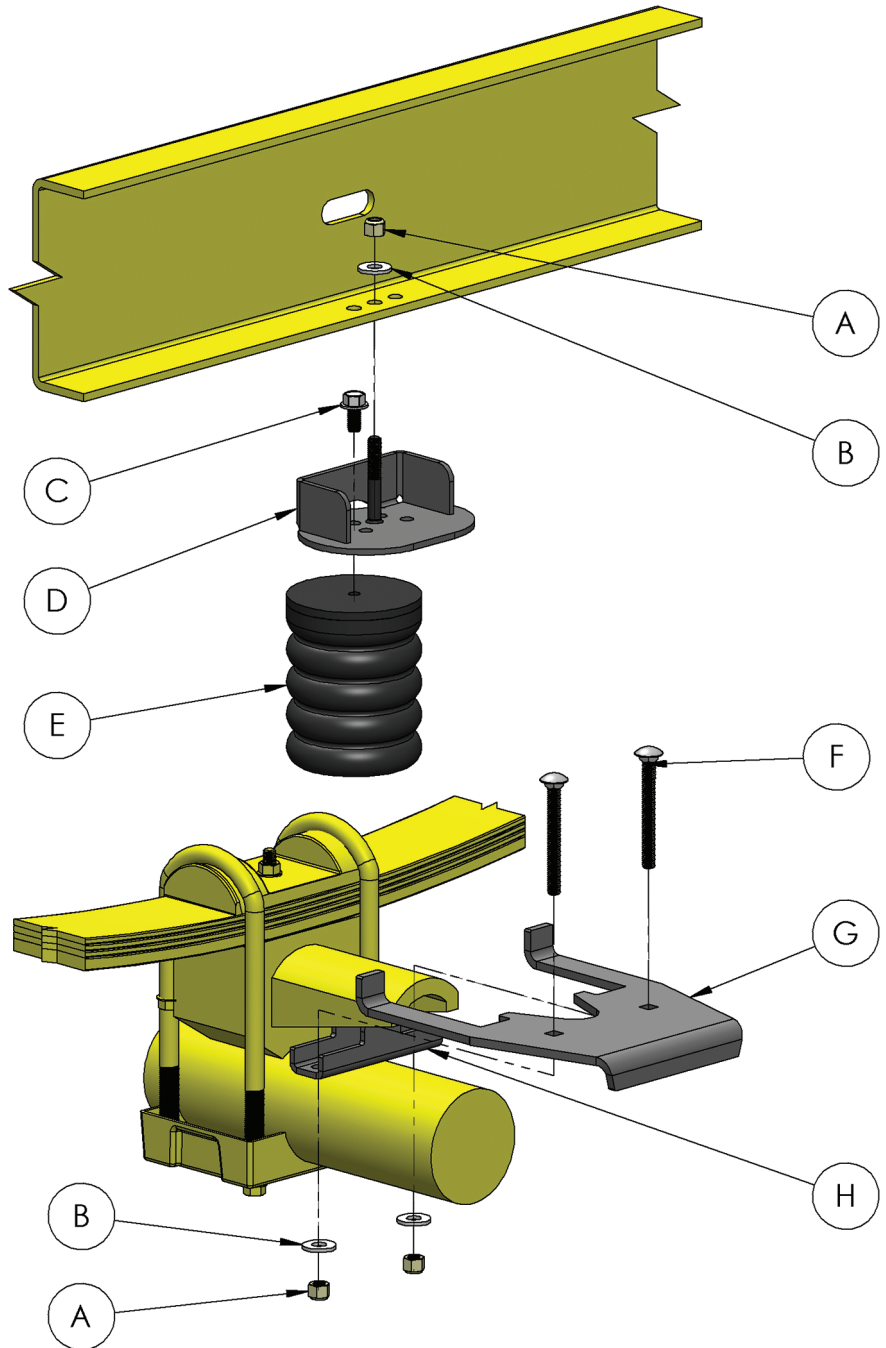

SuperSprings International, Inc.

505 Maple Avenue
Carpinteria, CA 93013

Technical Support
+1 (805) 745-5553
tech@supersprings.com

supersprings.com

⚠️ Never exceed the manufacturer's Gross Vehicle Weight Rating (GVWR) located on your vehicle's identification tag.

SAFETY NOTICE: We recommend installation be done by a professional or persons with sound mechanical knowledge.

WARNING: These instructions are a general guide for installation. SuperSprings International, Inc. assumes no liability for the actual installation process. Consumers and installers should apply common automotive safety practices when raising and working on any vehicle. **Do not put yourself in a position where, if the vehicle were to move**

unexpectedly, you may be injured. SuperSprings' products are designed to improve vehicle ride quality. Do not load any vehicle beyond the manufacturer's specifications.

BEFORE INSTALLATION: Ensure the vehicle is on a level surface, the parking brake is ON, with the ignition OFF, and place blocks in front of and behind the front tires to prevent the vehicle from moving.

DURING AND/OR AFTER INSTALLATION: Ensure emergency brake cables are not touching the SuperSprings. Secure any cables out of the way with zip ties or by re-routing. **Ensure all A/C lines, brake cables and frame are clear of contact or interference.**

1. Park vehicle on level hard surface. Place wheel blocks in front and behind the front wheels to prevent rolling. Observe all safety precautions and wear safety glasses.
2. Raise the rear of the vehicle allowing the axle to hang free and rest the frame on the safety jack stands rated for the weight of the vehicle. Removal of the rear wheels is optional.
3. Starting on the driver's side unbolt and remove the factory jounce bumper from the underside of the frame and set aside. Some older model trucks have convoy clips that will interfere with the brackets. The convoy clips need to be removed before installation of the SumoSprings. To remove the convoy clips, grind or drill out the rivets that hold it to the frame.
4. Assemble the parts as indicated in the diagram. Attach the **SumoSprings Black [-40]** (ITEM E) to the **mounting bracket** (ITEM D) using the **3/8-16 x 3/4" bolt** (ITEM C). Be sure to use the hole that will be closest to the rear and furthest outboard toward the wheel of the vehicle.
5. Attach the mounting bracket (ITEM D) to the underside of the frame using the **3/8 flat washer** (ITEM B) and **3/8-16 lock nut** (ITEM A). Install mounting stud in the same hole as the factory bump stop.
6. If more support is required, install the 1" spacer between bracket and SumoSprings using the **3/8-16 x 1-3/4" bolt** (ITEM J).
7. Place the **jounce pad** (ITEM G) onto the bump stop contact perch and slide the two legs under the leaf pack so that the two tangs are facing up on the outside of the leaf pack when the Jounce pad sits flat on the contact perch.
8. Place two **3/8-16 x 3-1/2" carriage bolts** (ITEM F) through the square holes in the **jounce pad** (ITEM G)
9. Slide the **lower clamp** (ITEM H) under the contact perch with the rounded tabs facing up into the recess of the contact perch and position the **carriage bolts** (ITEM F) through the holes of the **lower clamp** (ITEM H).
10. Using one **3/8 flat washer** (ITEM B) and **3/8-16 lock nut** (ITEM A) on each **carriage bolt** (ITEM F) secure the **jounce pad** (ITEM G) to the contact perch. Tighten securely, but do not over tighten or the brackets could bend.
11. Repeat steps three through six on the passenger's side of the vehicle.
12. If rear wheels were removed you can now reinstall the rear wheels and torque wheel nuts to manufacturers spec.
13. Jack up vehicle, remove safety jack stands.
14. Remove wheel blocks from the front wheels.
15. Fill out warranty card and send to SuperSprings. The warranty card is an attached document.

SuperSprings International, Inc.

505 Maple Avenue
Carpinteria, CA 93013

Technical Support

+1 (805) 745-5553
tech@supersprings.com

supersprings.com



Never exceed the manufacturer's Gross Vehicle Weight Rating (GVWR) located on your vehicle's identification tag.

SAFETY NOTICE: We recommend installation be done by a professional or persons with sound mechanical knowledge.

WARNING: These instructions are a general guide for installation. SuperSprings International, Inc. assumes no liability for the actual installation process. Consumers and installers should apply common automotive safety practices when raising and working on any vehicle. **Do not put yourself in a position where, if the vehicle were to move**

unexpectedly, you may be injured. SuperSprings' products are designed to improve vehicle ride quality. Do not load any vehicle beyond the manufacturer's specifications.

BEFORE INSTALLATION: Ensure the vehicle is on a level surface, the parking brake is ON, with the ignition OFF, and place blocks in front of and behind the front tires to prevent the vehicle from moving.

DURING AND/OR AFTER INSTALLATION: Ensure emergency brake cables are not touching the SuperSprings. Secure any cables out of the way with zip ties or by re-routing. **Ensure all A/C lines, brake cables and frame are clear of contact or interference.**