



**BX3225 Installation Instructions
2003-04 Pontiac Sunfire Coupe**

Serial No.

Strong As An Ox™

The headlight assembly, blinker assembly, front fascia, horn bracket, windshield washer reservoir and lower grill inserts are removed for baseplate installation. Lower grill inserts will not be re-installed. Drilling is required. The BX8869 is available for the vehicle. Attachment Tabs are 24 inches center to center and a height of 14 inches.



1. Remove the seven push pins from the top side of fascia's black plastic cover.



2. Using the 10MM socket, remove the metric bolt on blinker assembly brace, remove one phillips screw, unplug electrical and set aside, both sides.



3. Remove two metric bolts from headlight assembly with the 10MM socket, pull forward, unplug electrical and set aside, both sides.



4. On the back side of fog lights remove one push pin, both sides.



5. Just forward of front tire, on wheel well plastic, remove one push pin and two metric bolts with the 7MM socket, both sides.



6. Using the 7MM socket, remove three metric bolts from passenger's side and two bolts on the driver's side.



Strong As An Ox™



7. Remove the three metric bolts just forward of the front tire, on the bottom side of fascia, both sides.



8. Just forward of front tire, on lower black plastic remove two metric bolts on the passenger's side and one on the driver's side, using the 7MM socket.



9. Remove metric bolt from fascia corner, on inside of fender well using the 10MM socket, both sides.



10. Just behind headlight assembly, are two metric bolts to be removed using the 10 MM socket, both sides.



11. Remove two christmas tree clips on lower grill just under metal bumper, set lower grill insert aside. **Lower grill insert will NOT be reinstalled.**



12. Using the 13MM socket, remove metric bolt from horn bracket and set aside.



Strong As An Ox™



13. Remove three metric bolts from windshield washer reservoir on driver's side. Using the phillips screw driver, remove screw from tubing on reservoir and set aside.



15. Using item 1 as a template, drill all remaining holes on end plates with the 13/32" drill bit, both sides. Insert item 2 into opening on the bottom frame to align with drilled hole. Tighten items 3 and 4 according to drawing on last page, both sides. **Be sure and use loctite on all bolts before tightening. Torque all bolts according to torque chart in General Instructions.**

16. Reinstall horn bracket, windshield washer reservoir, fascia and headlight assemblies. **Be sure all electrical components and hoses are plugged in properly.**

17. The dimensional variations between otherwise identical cars can be considerable. While the location and size of the holes in the baseplate were designed to allow for easy installation, it may be necessary to file a hole slightly to allow a bolt to clear.

18. Install the tow bar and safety cables according to the instructions included in their packages.

19. Do **not** substitute other devices if the tow bar pin and clip are lost.

20. **DEALER OR INSTALLER: BE CERTAIN THE USER RECEIVES THE INSTRUCTION SHEET.**



14. On bottom center of metal bumper, align baseplate's (item 1) upper hole, clamp in place with vise grip. Using item 1 as a template, drill upper hole with the 13/32" drill bit, both sides. Insert items 2 into opening on the end of metal bumper to align with drilled hole and tighten items 3 and 4 according to drawing on last page, both sides. **Be sure and use loctite on all bolts before tightening. Torque all bolts according to torque chart in General Instructions.**





Strong As An Ox™

Tools Required

7MM Socket
13MM Socket
Phillips Screw Driver

10MM Socket
Loctite
Vise Grips

9/16" Socket
13/32" Drill Bit

Parts List

Ref. No.	Qty.	Part No.	Description
1	1	61-5865	Weldment, Base Plate, BX3225
2	10	61-5208	3/8" Nut Plate, with Wire
3	10	201-0440	3/8-16 x 1 1/2 Bolt, Grd. 5, ZP
4	10	203-0010	3/8 Lock Washer, ZP
5	2	201-0553	1/4-20 x 1/2 Hx. Wshd, Type F Screw
6	2	202-0047	#10-32 Hex Nut
7	2	203-0054	#10 Lock Washer
8	2	201-0192	#10-32 x 1/2 Slot, Rd. Hd. Screw
9	2	101-5822	Adapter, 4 Way Connector
10	2	62-3469	Attachment, Assembly, SF/ LB (R)
	2	226-0046	Baseplate Safety Cable, 36" CL III (Not Shown)
	2	229-0359	Quicklink, 3/8, ZP (Not Shown)
	2	290-0437	Receiver, Cap Plug (BLK) (Not Shown)



Location for the Bx8869 on driver's side tail light assembly.

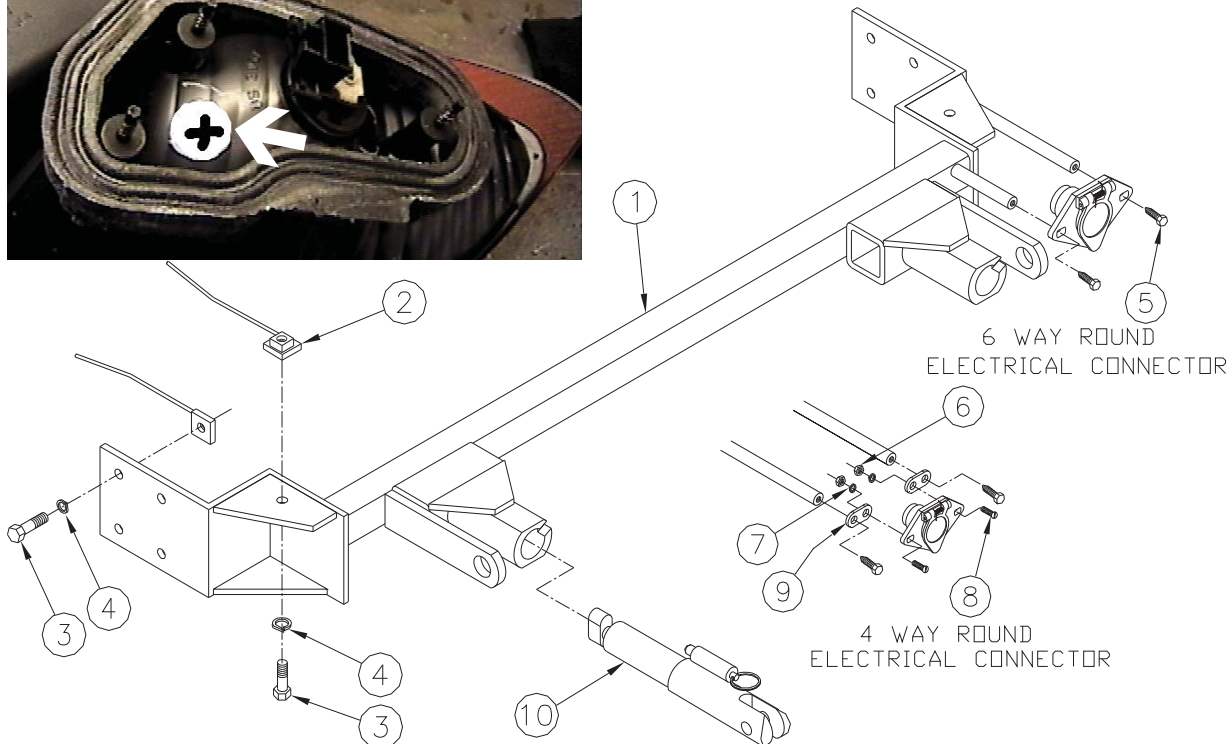

IMPORTANT: Use only genuine factory replacement parts on your Base Plate. Do not substitute homemade or nontypical parts. If a bolt is lost or in need of replacement, for your safety and the preservation of your Base Plate, be sure to use a replacement bolt of the same grade (Usually Grade 5, refer to parts list). Repair parts may be ordered through your nearest **Blue Ox** dealer or distributor.